

Lancia Flavia 1.8 Vignale (injection) 815.435

NOTES

1. The associated diagrams illustrate point-to-point wiring connexions between components.
They are copied from those included in the owners instruction manual.
Various production series of the cars may reveal minor changes.
2. Component numbers correspond to those shown in the published diagrams and lists.
3. The first diagram follows the 12 volt supply to the fuse box. From the fuse box, the wiring to each component is composed as a complete circuit. Some wiring and component connexions are common to more than one circuit, and may be duplicated for easy reference.

Colour Code

R = Red
Y = Yellow
X = Not shown
BL = Blue
BN = Brown
GY = Grey
GN = Green
WH = White
HZ = Hazel
PK = Pink

Letter Code

F = Front
B = Back
RH = Right Hand
LH = Left Hand
HB = High (main) beam
LB = Low beam
JB = Plug-in junction box
LF = Line fuse
INR = Inner
OTR = Outer

Symbol Code

 Indicates part of a circuit showing only the terminals relevant to the circuit.

 Wiring interconnexion of 2 or more wires.

 From battery } General Rule
FUSE } - some exceptions

 Lamp or light

 Switch on/off

 Switch non locking (push)



Component list

1 = Battery	28 = Low beam filament	55 = Ammeter
2 = Alternator	29 = Front parking lamps	56 = Interior light and switch
3 = Voltage Regulator	30 = Front direction indicator	57 = Interior light door switch
4 = Starter Motor	31 = Direction indic. repeaters	58 = Main beam warning light
5 = Ignition coil	32 = Stop lights	59 = Radio
6 = Ignition distributor	33 = Headlamp flashing relay	60 = Fuel pump
7 = Alternator warning light	34 = Rear parking lamp filament	61 = Main beam wiring fuses
8 = Ignition key switch	35 = Rear dirn. indic. filament	62 = Boot light switch
9 = Fuse box	36 = Reverse lamps	63 = Boot light
10 = Instrument panel lights	37 = Number plate lamps	64 = Door open marker lamps
11 = Inst. panel lights switch/rheostat	38 = RH dirn. indic. warning light	65 = Cigar lighter
12 = Direction indic. flasher	39 = LH dirn. indic. warning light	66 = Rear shunt block
13 = Direction indic. flasher control	40 = Stop light switch	67 = Bloster anti-theft
14 = Headlamp flash contact	41 = Alternator excitation circuit resistor 80 ohms 4W	68 = Plug-in junction
15 = Headlamp control relay	42 = Choke+h/brake warning light	69 = H/lamp flasher contact assembly
16 = Low beam switch	43 = H/brake warning light switch	70 = Fuel low pressure warning light switch
17 = Dip switch push button	44 = Horn electro-compressor	71 = Fuel low pressure warning light
18 = Parking lamps switch	45 = Horn relay	72 = Cold-start electrovalve
19 = Parking lamps warning light	46 = Horn control	73 = Cold-start electrovalve cut-off thermocontact
20 = Engine compartment light	47 = Reversing lamp switch	74 = Cold-start device warning light contacts
21 = Engine comp. light switch	48 = Low oil pressure light & switch	
22 = H/lamp flashing control	49 = Water temp. gauge sender	
23 = Windscreen wiper switch	50 = Water temperature gauge	
24 = Windscreen wiper motor	51 = Fuel gauge	
25 = Heater fan switch	52 = Fuel gauge sender	
26 = Heater fan motor	53 = Low fuel warning light	
27 = Main beam filament	54 = Plug-in socket	

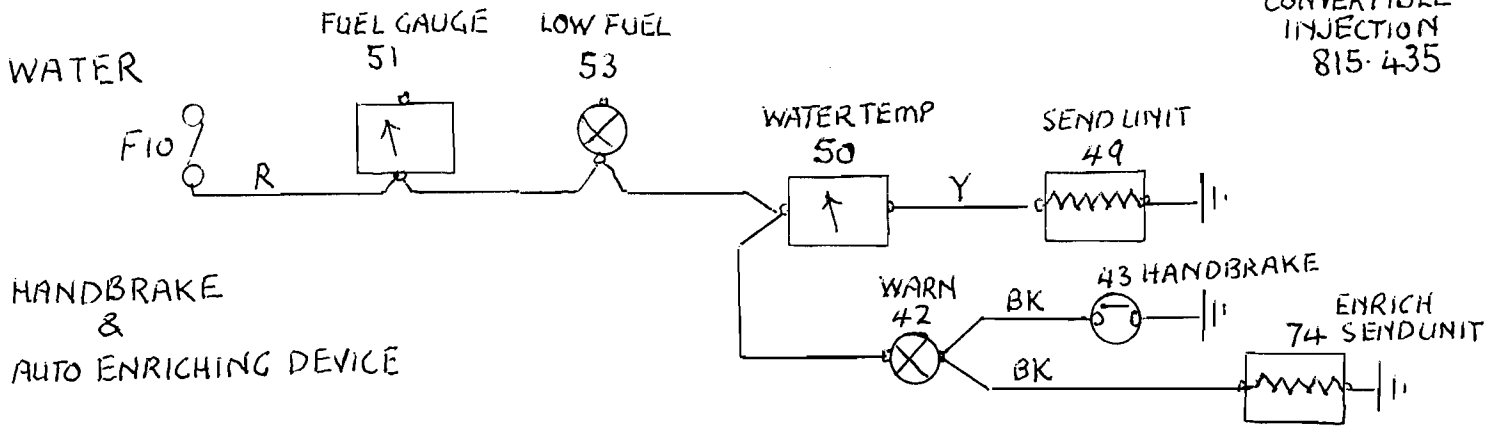

LIGHTING CIRCUITS

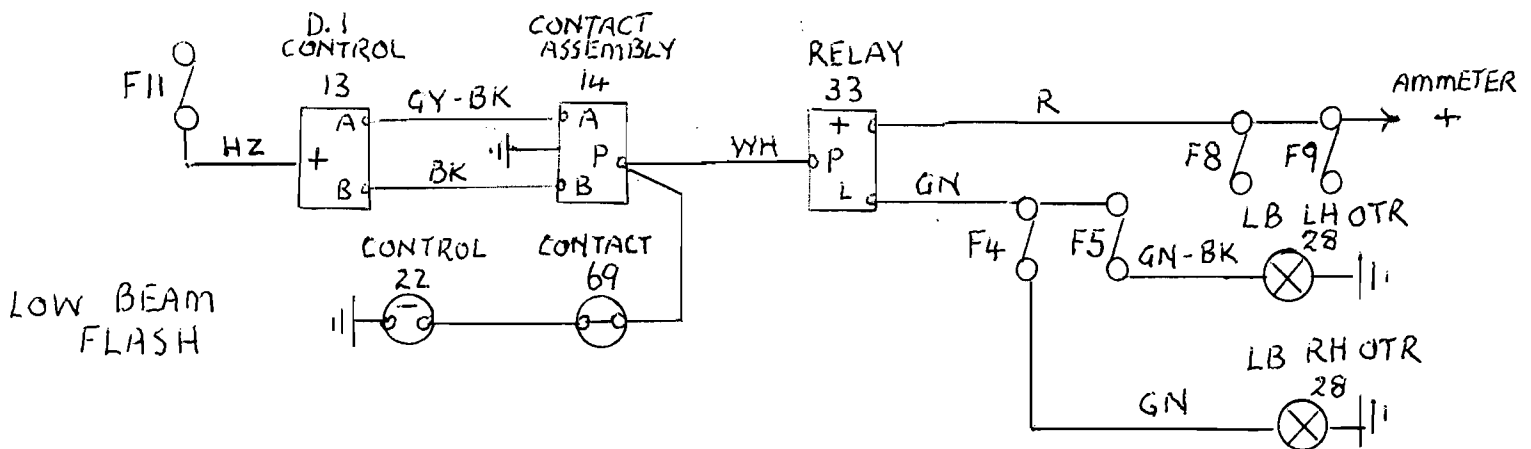
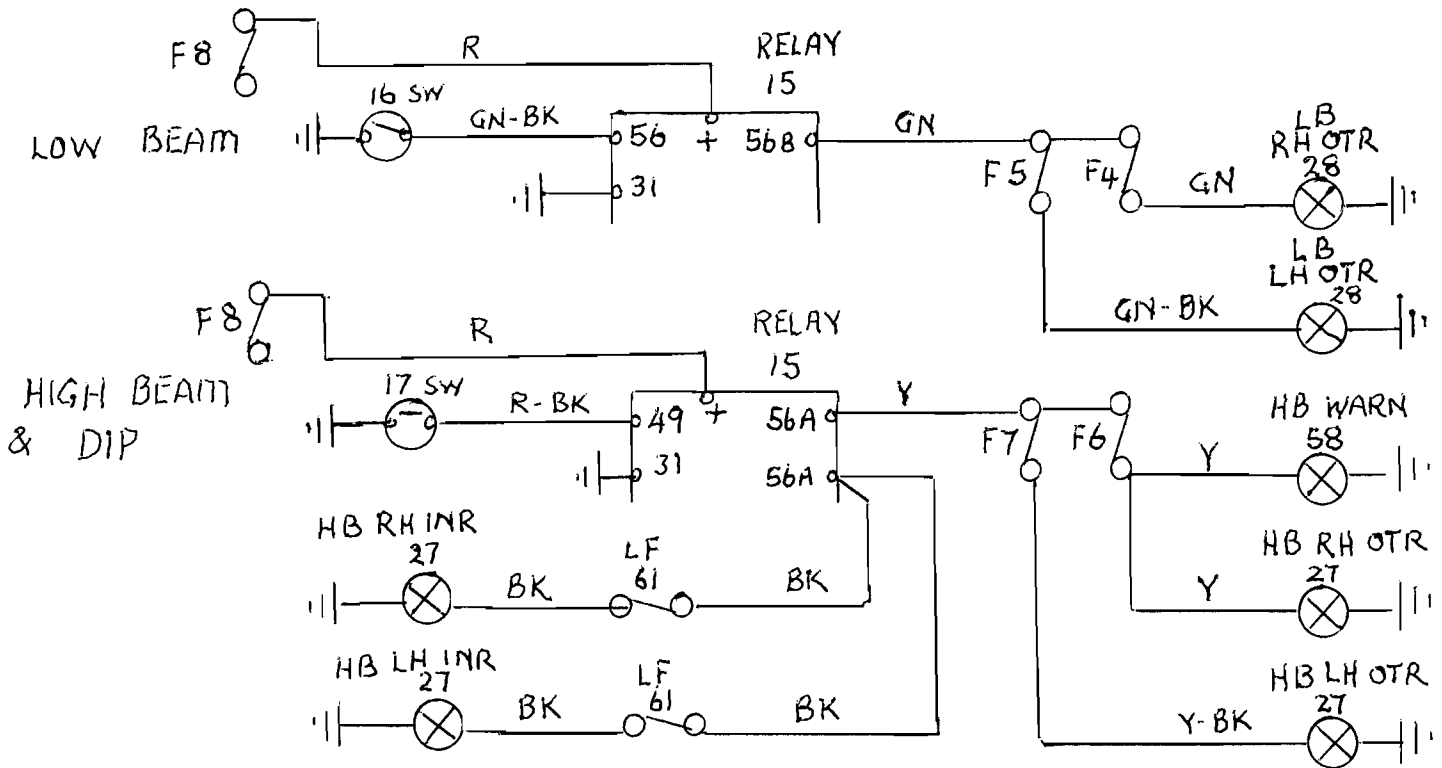

LIGHTING (CONT)

LANCIA
FLAVIA
CONVERTIBLE
INJECTION
815-435

PARKING

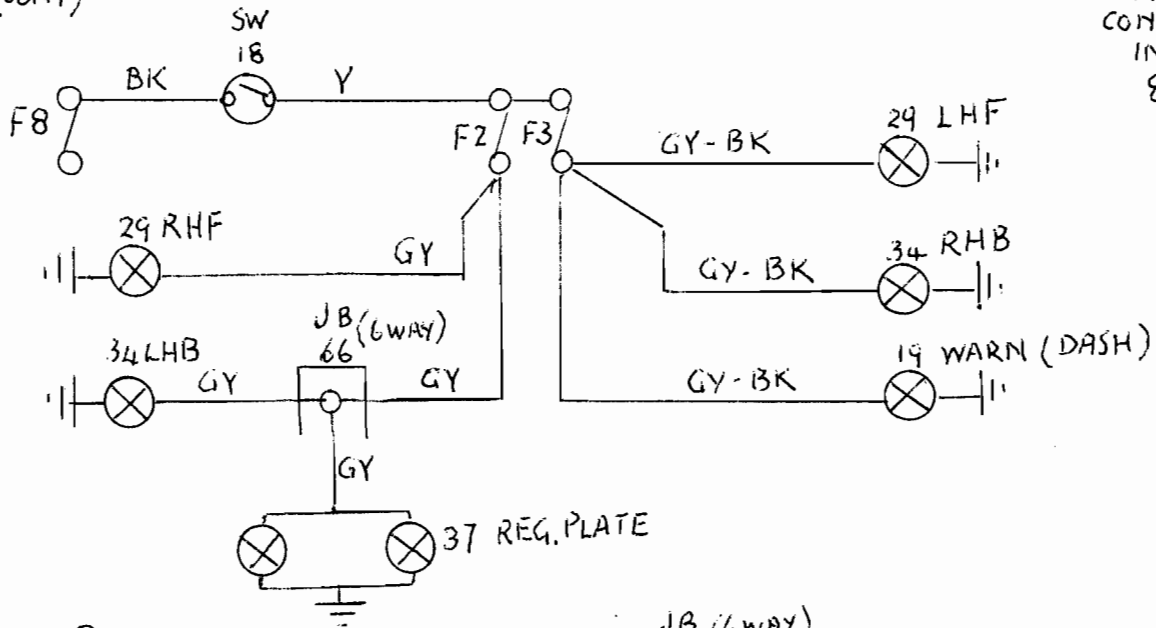

REVERSE

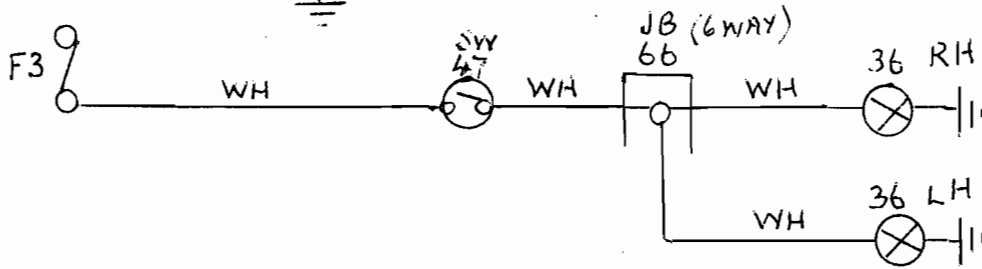

INTERIOR

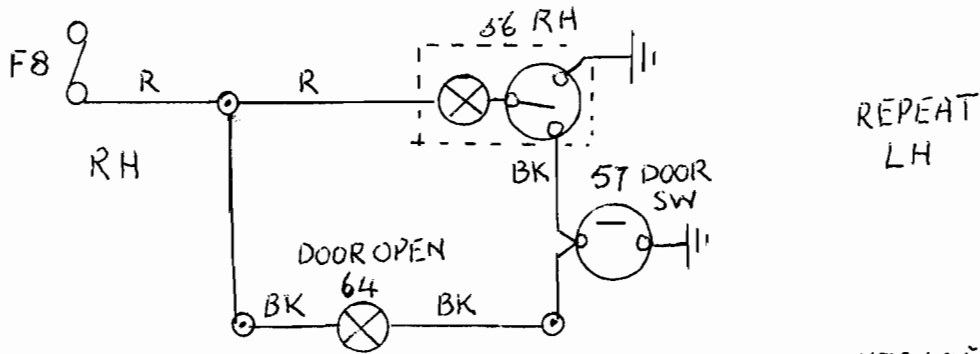

INSTRUMENT PANEL

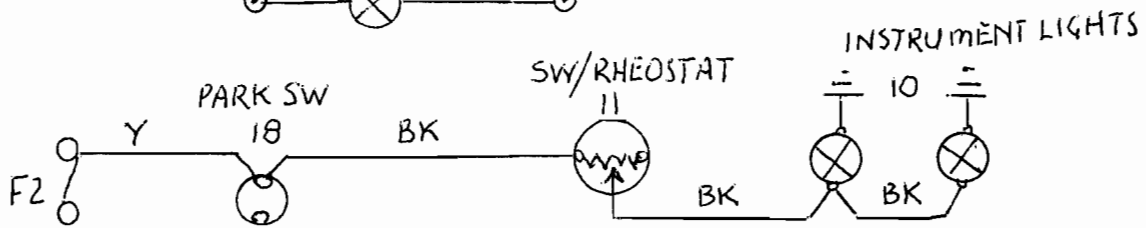

ENGINE BAY
&
BOOT

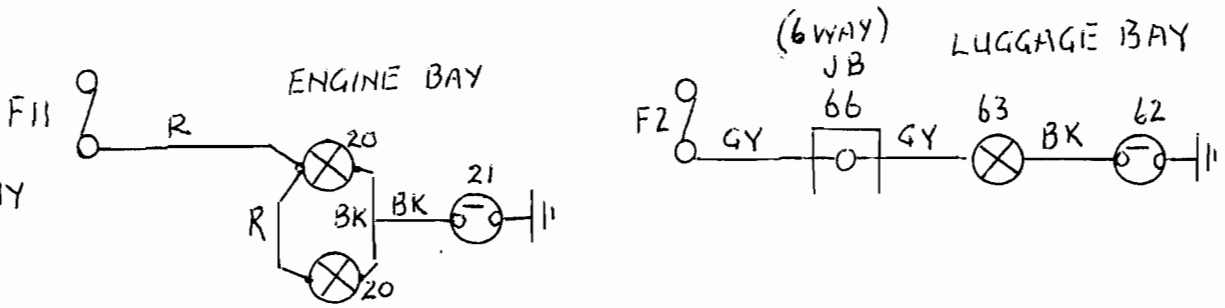

LIGHTING (CONT)

LANCIA
FLAYIA
CONVERTIBLE
INJECTION
815.435

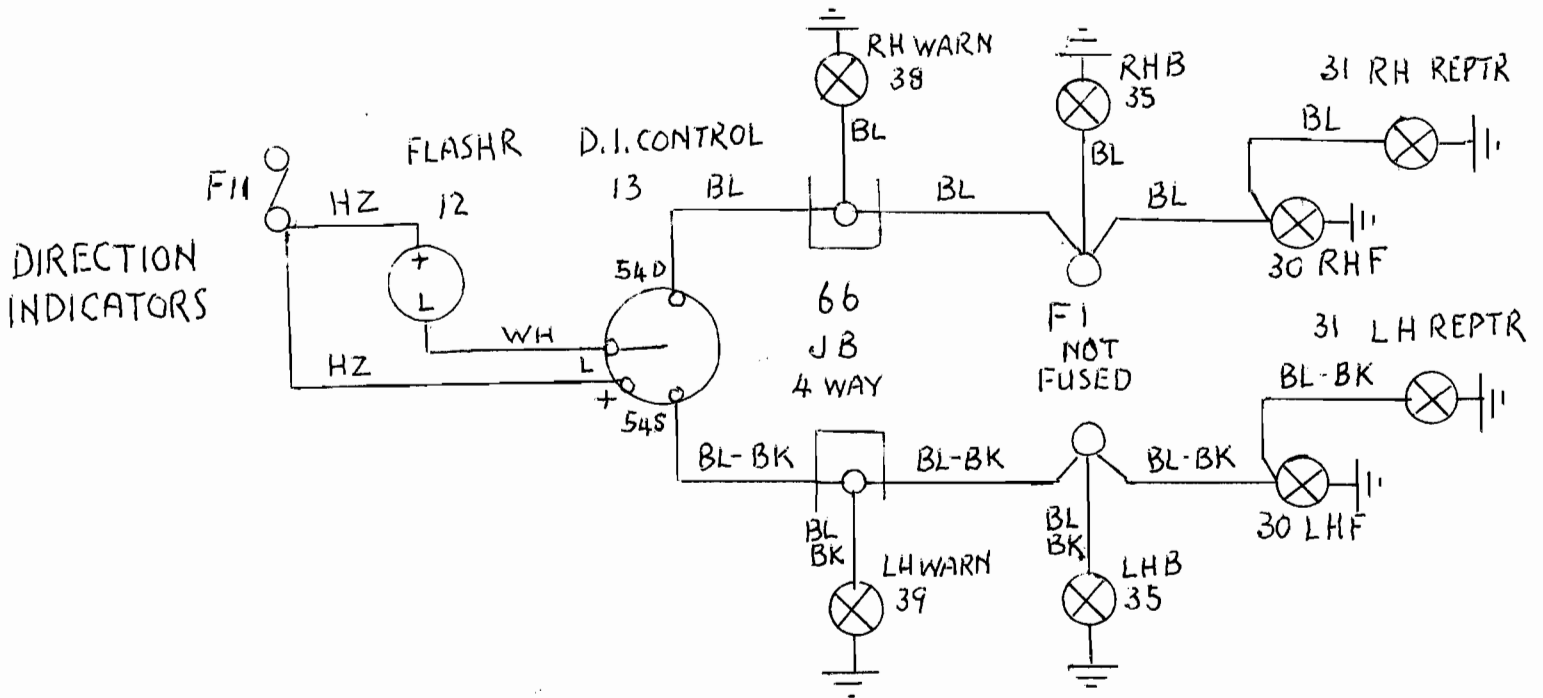
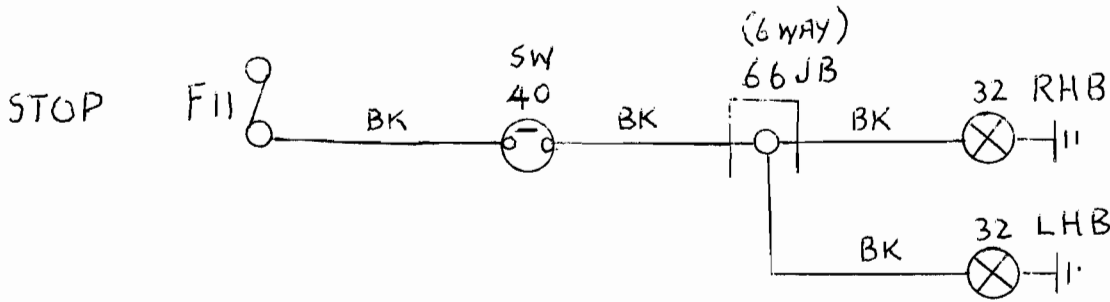

MISC SERVICES

